

CS SERIES

Instruction manual

Basic connection

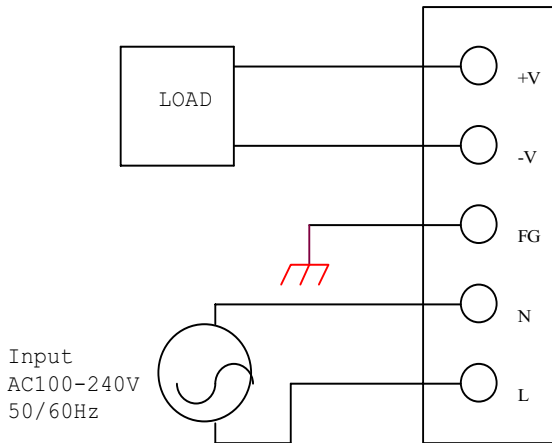

NOTE:

- A: To meet safety requirements, the power supply terminal must not be used directly as the external terminations of any equipment.
- B: For safety as well as improved noise, ensure secure connection of the FG terminal to the ground terminal of the equipment.
- C: To avoid excessive voltage drop and for improved noise, short and thick wire should be used to connect the load

Parallel Operation

This supply can be operated the following ways.

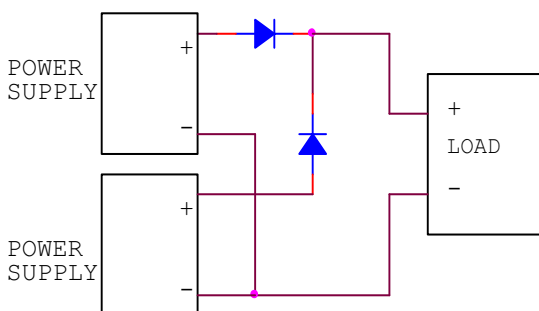

Series Operation

This supply can be operated the following ways.

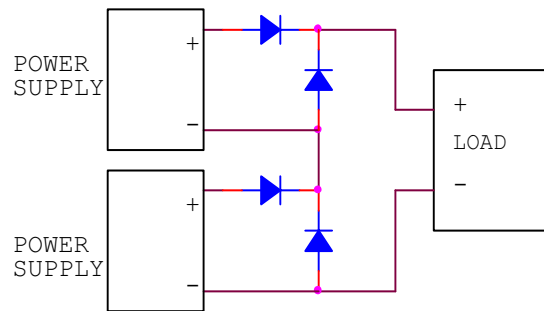

(for 3.3V-5V model only)

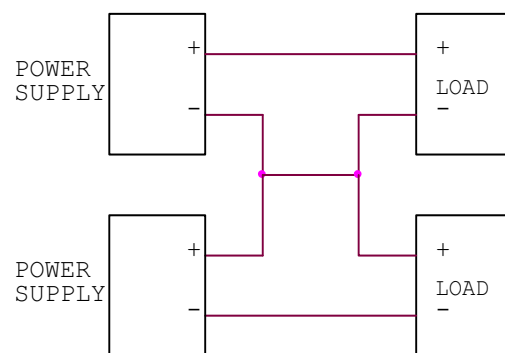
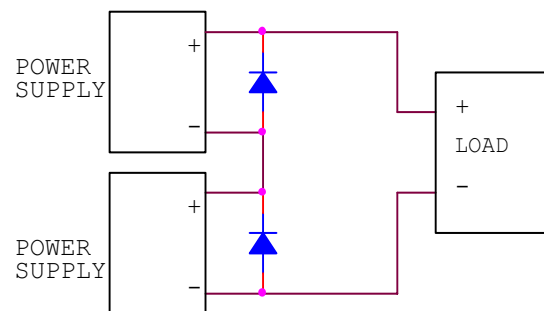

Choose a diode in accordance with voltage, power dissipation and heat radiation

CS SERIES

Instruction manual

Output Voltage Range

By means of VR1. On the front panel, output voltage can be adjusted within the range of $\pm 10\%$. Turning clockwise increases the voltage.

Caution: Increase the voltage excessively, i.e, more than nominal $+10\%$, may cause the over-voltage protection(OVP) device to operate.

Output Ripple & Noise Measurement Method

The standard measurement for output ripple and noise are based on normal probe with 60MHz bandwidth scope. Upon measurement of the ripple voltage, make sure that the oscilloscope probe leads are not too long.

Over Current Protection

The CS Series is equipped with an over current protection circuit. When the short or overload condition is removed, the output will automatically recover. This setting is fixed and cannot be varied externally. If the short or overload condition continues, the power module could be damaged due to the heat condition

Over Voltage Protection

The CS Series is equipped with an OVP(over voltage protection) circuit. When the OVP trigger, the output will be shut down. The input must be taken out(for at least five seconds), and then reinputted manually. Otherwise, the module will not output.

Maximum Line Regulation

Maximum line regulation is maximum output voltage change when the input voltage is slowly varied within the input voltage range.

Maximum Load Regulation

Maximum load regulation is maximum output voltage value change when varying the load current slowly within the standard output current range.

Storage Temperature

Please note that sudden temperature changes can cause condensation buildup, and other harmful effects to each terminal solder

Storage Humidity

High temperature and humidity can cause the terminal on the module to oxidize. The quality of the solder will become worse.

Fuse rating

Rating : 250V 2.5A(CS15),250V 3.15A(CS30)
250V 4A(CS50), 250V 4A(CS75)
250V 4A(CS100), 250V 6.3A(CS150)
250V 6.3A(CS200)

Type : Time-Lag

UL/CSA or IEC approved type should be used to meet safety requirements. When changing fuse ensure that the same type and ratings used.

Avoid using fast-blow fuse.

CS SERIES

Instruction manual

Withstand Voltage

CS series are designed to withstand 3KVAC(10mA) 1 minute between input-output , 2KVAC(10mA) 1 minute between input-FG , and 500VAC(10mA) 1 minute between output-FG.

For the withstand voltage test, the applied voltage must be increased gradually from zero to the testing value, and then decreased gradually at shut down . Especially stay away from use of a timer. Where a pulse of several times the applied voltage can be generated

Input-FG

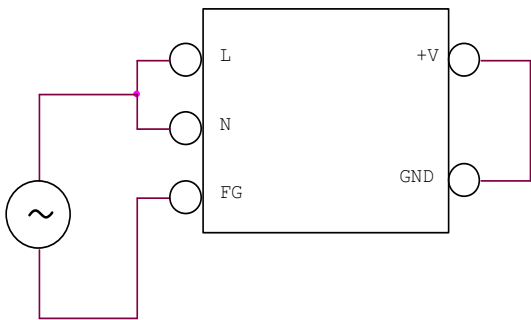

2KVAC, one minute, 10mA

Input-Output

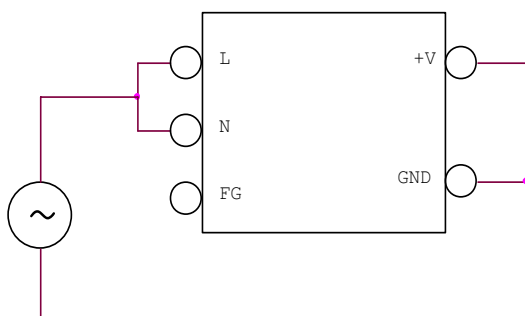

3KVAC, one minute, 10mA

Output-FG

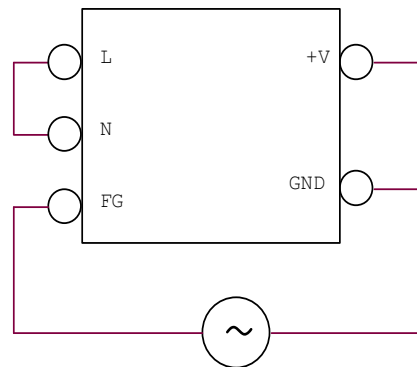

500VAC, one minute, 10mA

Isolation Resistance

The isolation resistance is more than 70M Ω at 500 VDC when tested with a DC isolation tester between the output and the case. Make sure that during testing, the isolation tester does not produce a high pulse when the applied voltage is varied. Ensure that the tester is fully discharged after the test.

Output-FG

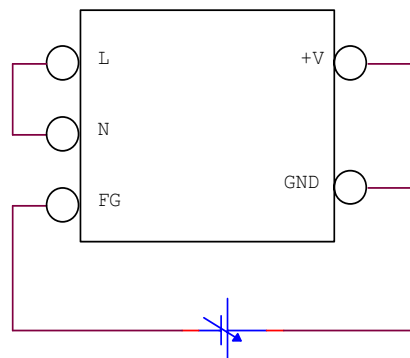

CS150 Series

TECHNICAL DATA

()

POWER  PLAZA



1.

2. Technical Data

2.1 Line Regulation & Load Regulation

2.2 Inrush Current

2.3 Output Ripple & Noise

2.4 Rising Time

2.5 Hold up Time

2.6 Start up Time

2.7 Dynamic Load Regulation

2.8 Overshoot

2.9 Over Voltage Protection

2.10 ()

2.11 ()

3. Case Dimension

1.

	NAME	MODEL NO.	MAKER
1	AC SOURCE	61602	CHROMA
2	DIGITAL POWER METER	WT110	YOKOGAWA
3	DIGITAL MULTIMETER	34401A	AGILIENT
4	MULTIMETER	FLUKE 73	FLUKE
5	ELECTRONIC DC LOAD	EUL - 300D	FUJITSU DENSO
6	ELECTRONIC DC LOAD	EUL - 600K	FUJITSU DENSO
7	OSCILLOSCOPE	9374L	LECROY
8	10:1 Probe (500MHz)	PP006A	LECROY
9	100 : Probe (100MHz)	CP - 241	STACK
10	CURRENT Probe (30MHz)	AP015	LECROY
11	DIFFERENTIAL Probe	P5200	TEKTRONIX
12	WITHSTADING VOLTAGE TESTER	TOS5051	KIKUSUI
13	M HI TESTER	3117 - 14	HIOKI
14	LEAKAGE CURRENT TESTER	TYPE 3226	YOKOGAWA
15		uPS1000	YOKOGAWA
16	LISN	Model 3810/2	EMCO
17	EMC ANALYZER	E7401A	HEWLETT PACKARD
18			
19			
20			

2. Technical Data

2.1 Line Regulation & Load Regulation

< CS150 - 3R3 > 3.3V / 30.0A

Condition Ta : 25

Iout / Vin	90Vac	110Vac	132Vac	170Vac	220Vac	264Vac	Line Regulation	
0%	3.30 V	3.30 V	3.30 V	3.30 V	3.30 V	3.30 V	0.0 V	0.0 %
50%	3.29 V	3.30 V	3.30 V	3.30 V	3.30 V	3.30 V	0.1 V	0.303 %
100%	3.29 V	3.29 V	3.29 V	3.29 V	3.29 V	3.29 V	0.0 V	0.0 %
Load	0.01 V	0.01 V	0.01 V	0.01 V	0.01 V	0.01 V		OK
Regulation	0.303 %	0.303 %	0.303 %	0.303 %	0.303 %	0.303 %	OK	

< CS150 - 05 > 5.0V / 30.0A

Condition Ta : 25

Iout / Vin	90Vac	110Vac	132Vac	170Vac	220Vac	264Vac	Line Regulation	
0%	5.00 V	5.00 V	5.00 V	5.00 V	5.00 V	5.00 V	0.0 V	0.0 %
50%	4.99 V	4.99 V	4.99 V	4.99 V	4.99 V	4.99 V	0.0 V	0.0 %
100%	4.99 V	4.99 V	4.99 V	4.99 V	4.99 V	4.99 V	0.0 V	0.0 %
Load	0.01 V	0.01 V	0.01 V	0.01 V	0.01 V	0.01 V		OK
Regulation	0.2 %	0.2 %	0.2 %	0.2 %	0.2 %	0.2 %	OK	

< CS150 - 12 > 12.0V / 12.5A

Condition Ta : 25

Iout / Vin	90Vac	110Vac	132Vac	170Vac	220Vac	264Vac	Line Regulation	
0%	12.02 V	12.02 V	12.02 V	12.02 V	12.02 V	12.02 V	0.0 V	0.0 %
50%	12.01 V	12.01 V	12.01 V	12.01 V	12.01 V	12.01 V	0.0 V	0.0 %
100%	12.01 V	12.01 V	12.01 V	12.01 V	12.01 V	12.01 V	0.0 V	0.0 %
Load	0.01 V	0.01 V	0.01 V	0.01 V	0.01 V	0.01 V		OK
Regulation	0.083 %	0.083 %	0.083 %	0.083 %	0.083 %	0.083 %	OK	

< CS150 - 15 > 15.0V / 10.0A

Condition Ta : 25

Iout / Vin	90Vac	110Vac	132Vac	170Vac	220Vac	264Vac	Line Regulation	
0%	15.01 V	15.01 V	15.01 V	15.01 V	15.01 V	15.01 V	0.0 V	0.0 %
50%	15.01 V	15.01 V	15.01 V	15.01 V	15.01 V	15.01 V	0.0 V	0.0 %
100%	15.01 V	15.01 V	15.01 V	15.01 V	15.01 V	15.01 V	0.0 V	0.0 %
Load	0.0 V	0.0 V	0.0 V	0.0 V	0.0 V	0.0 V		OK
Regulation	0.0 %	0.0 %	0.0 %	0.0 %	0.0 %	0.0 %	OK	

< CS150 - 24 > 24.0V / 6.3A

Condition Ta : 25

Iout / Vin	90Vac	110Vac	132Vac	170Vac	220Vac	264Vac	Line Regulation	
0%	24.01 V	24.01 V	24.01 V	24.01 V	24.01 V	24.01 V	0.0 V	0.0 %
50%	24.00 V	24.00 V	24.00 V	24.00 V	24.00 V	24.00 V	0.0 V	0.0 %
100%	24.00 V	24.00 V	24.00 V	24.00 V	24.00 V	24.00 V	0.0 V	0.0 %
Load	0.01 V	0.01 V	0.01 V	0.01 V	0.01 V	0.01 V		OK
Regulation	0.042 %	0.042 %	0.042 %	0.042 %	0.042 %	0.042 %	OK	

< CS150 - 48 > 48.0V / 3.2A

Condition Ta : 25

Iout / Vin	90Vac	110Vac	132Vac	170Vac	220Vac	264Vac	Line Regulation	
0%	48.0 V	48.0 V	48.0 V	48.0 V	48.0 V	48.0 V	0.0 V	0.0 %
50%	48.0 V	48.0 V	48.0 V	48.0 V	48.0 V	48.0 V	0.0 V	0.0 %
100%	48.0 V	48.0 V	48.0 V	48.0 V	48.0 V	48.0 V	0.0 V	0.0 %
Load	0.0 V	0.0 V	0.0 V	0.0 V	0.0 V	0.0 V		OK
Regulation	0.0 %	0.0 %	0.0 %	0.0 %	0.0 %	0.0 %	OK	

2. Technical Data

2.2 Inrush Current

TEST CONDITION

- 264Vac Input, Full Load Output
- -90 Input Start
- Inrush Current = Channel 1 × 10A

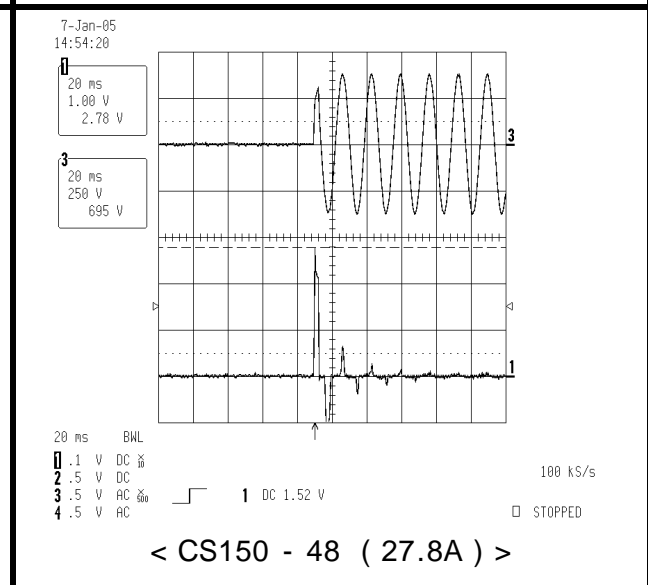
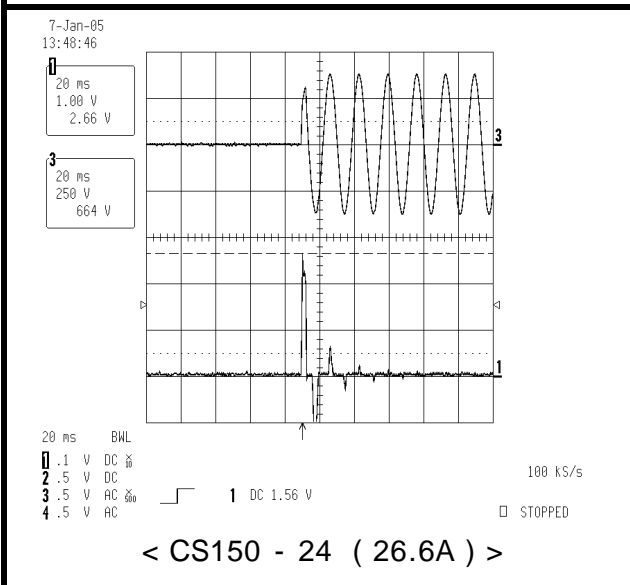
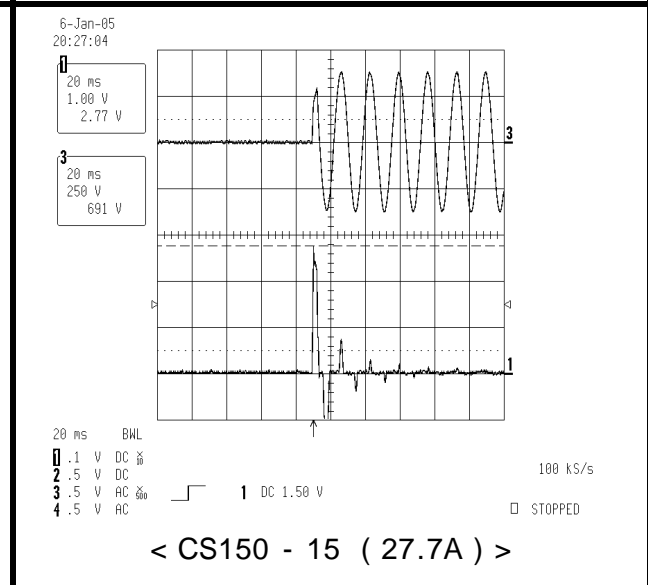
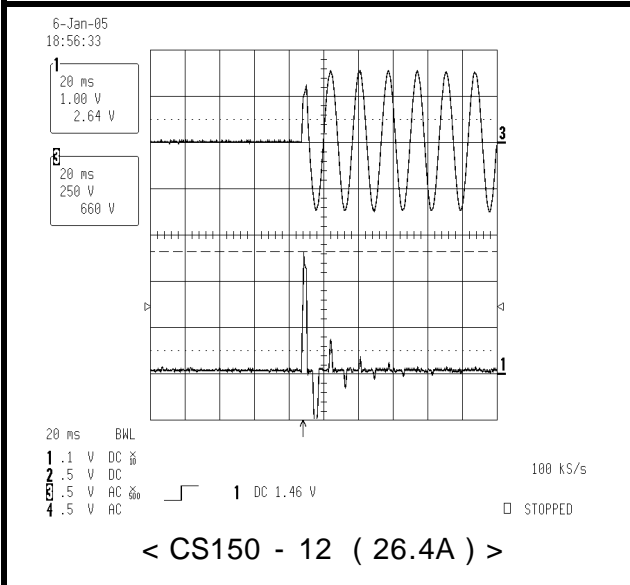
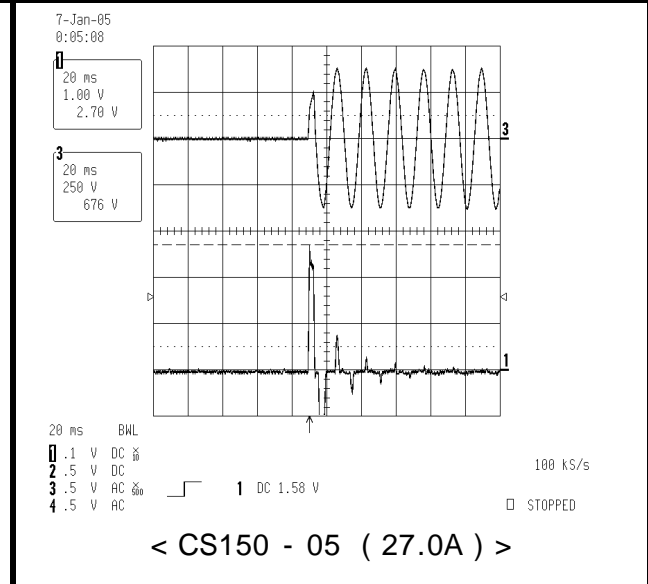
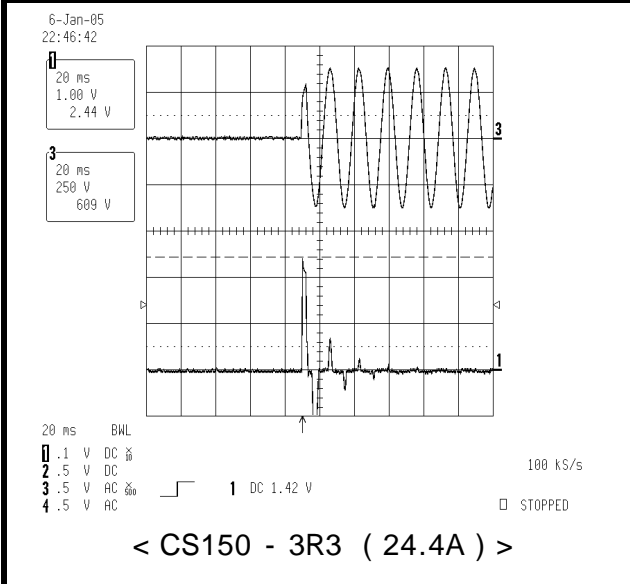

2. Technical Data

2.3 Ripple & Noise

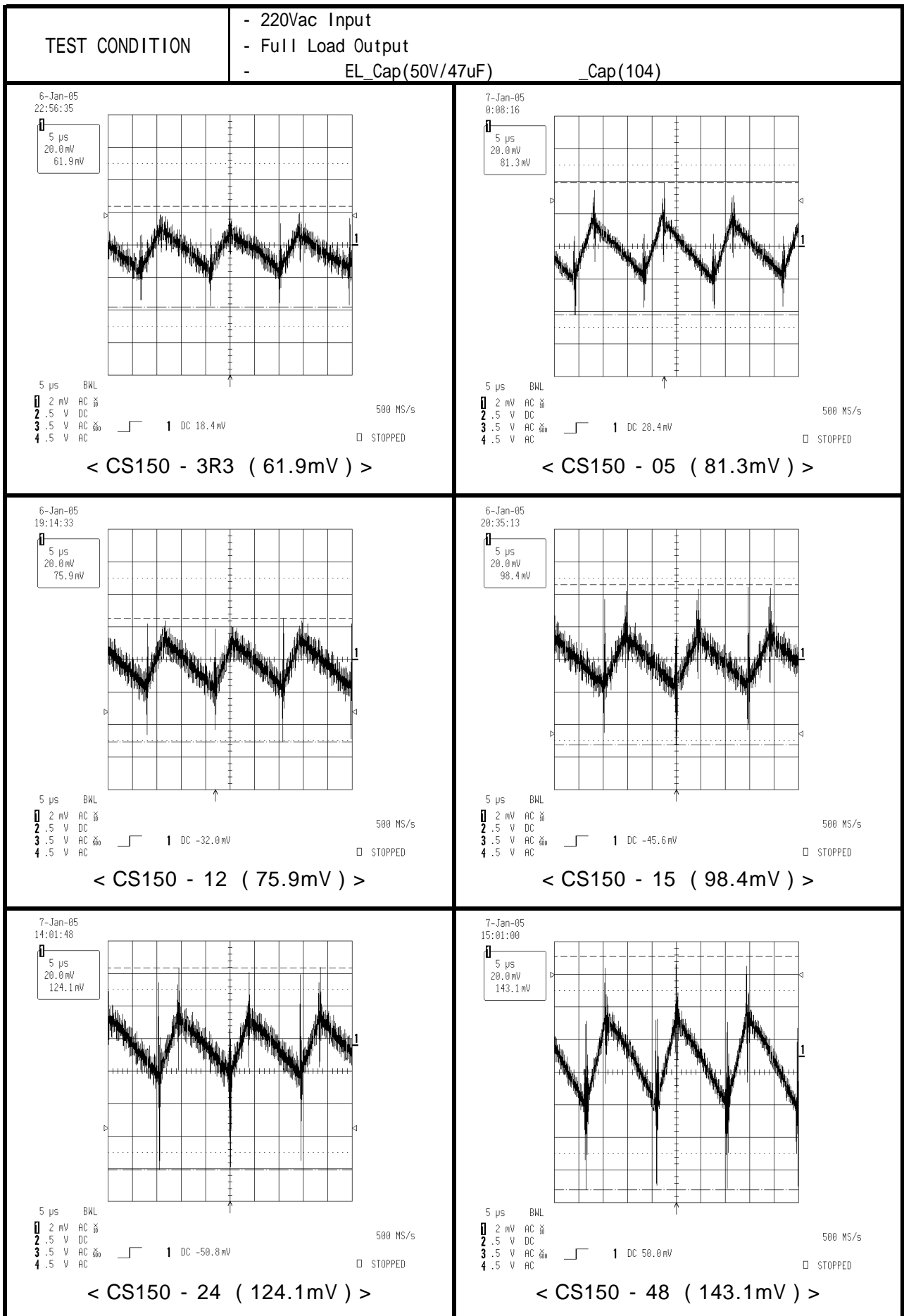

2. Technical Data

2.4 Rising Time

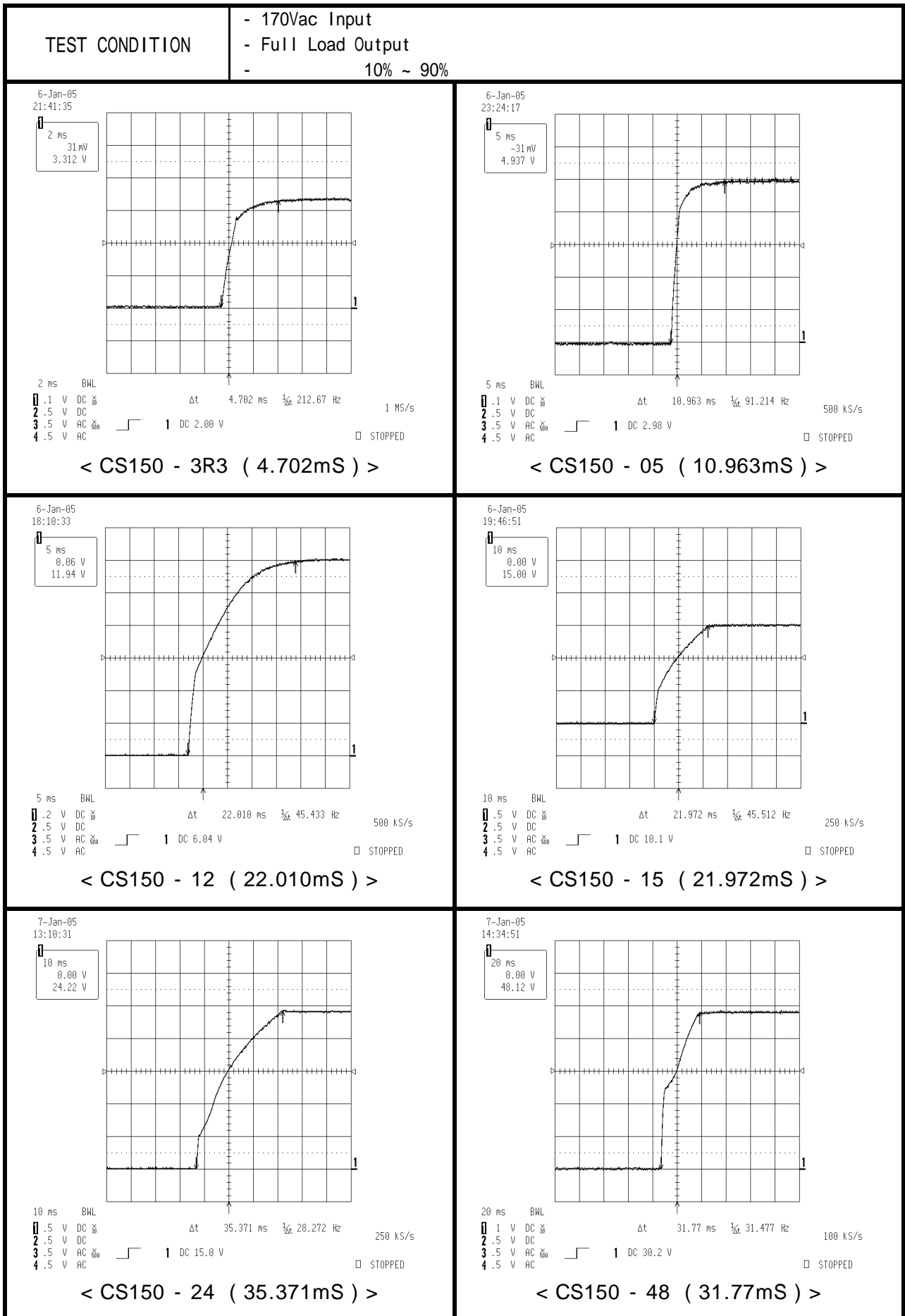

2. Technical Data

2.5 Hold up Time

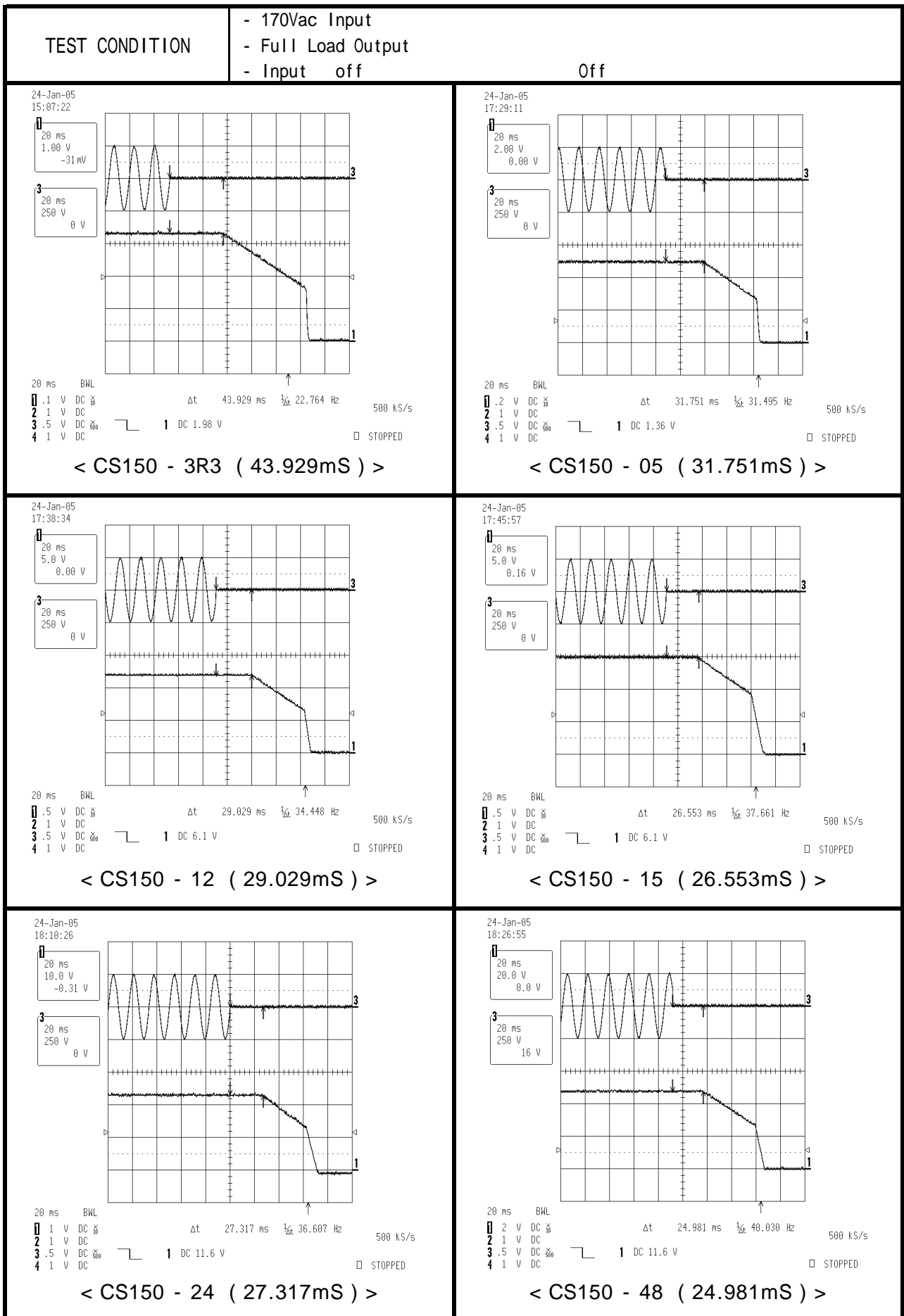

2. Technical Data

2.6 Start up Time

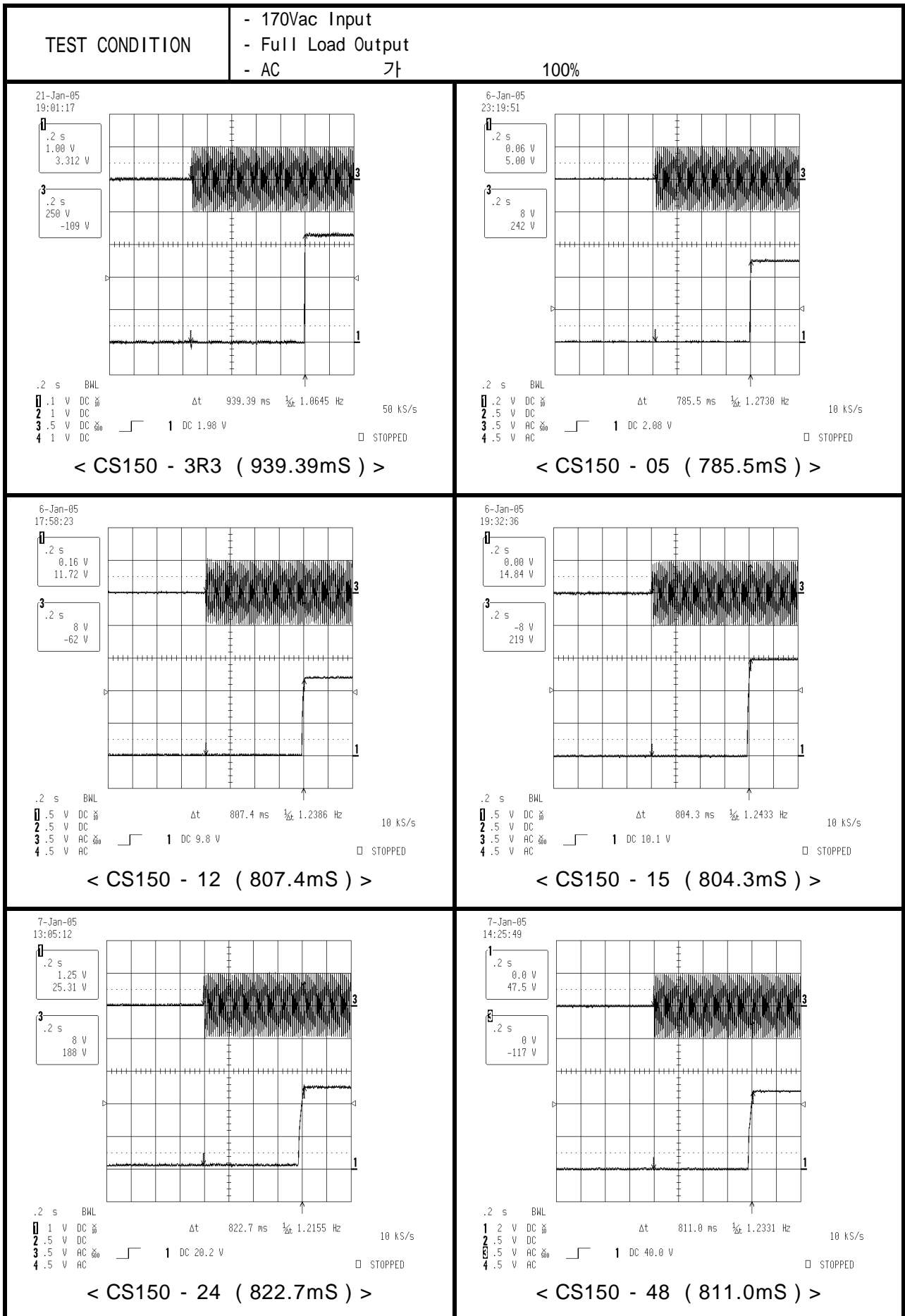

2. Technical Data

2.7 Dynamic Load

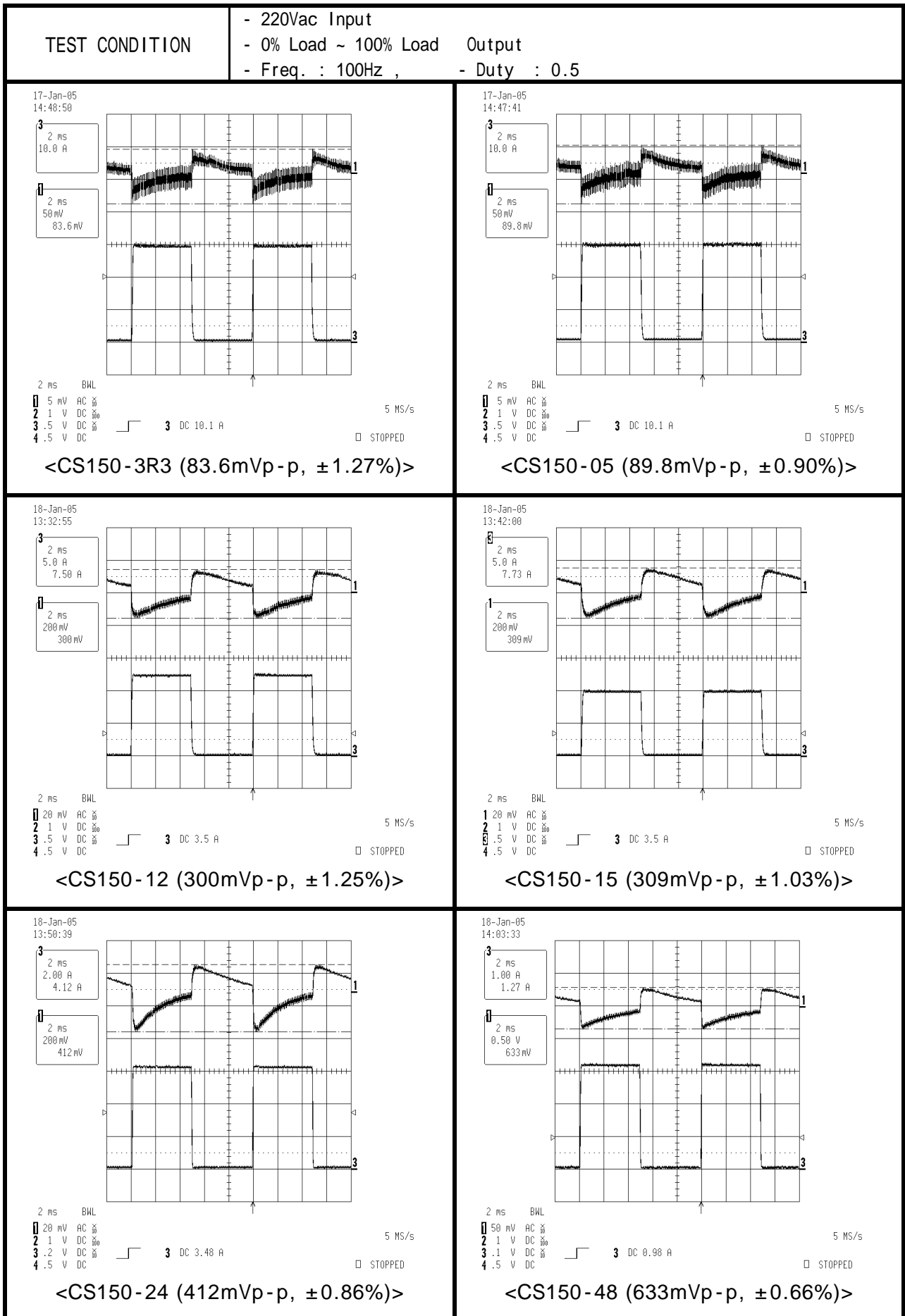

2. Technical Data

2.8 Over Shoot

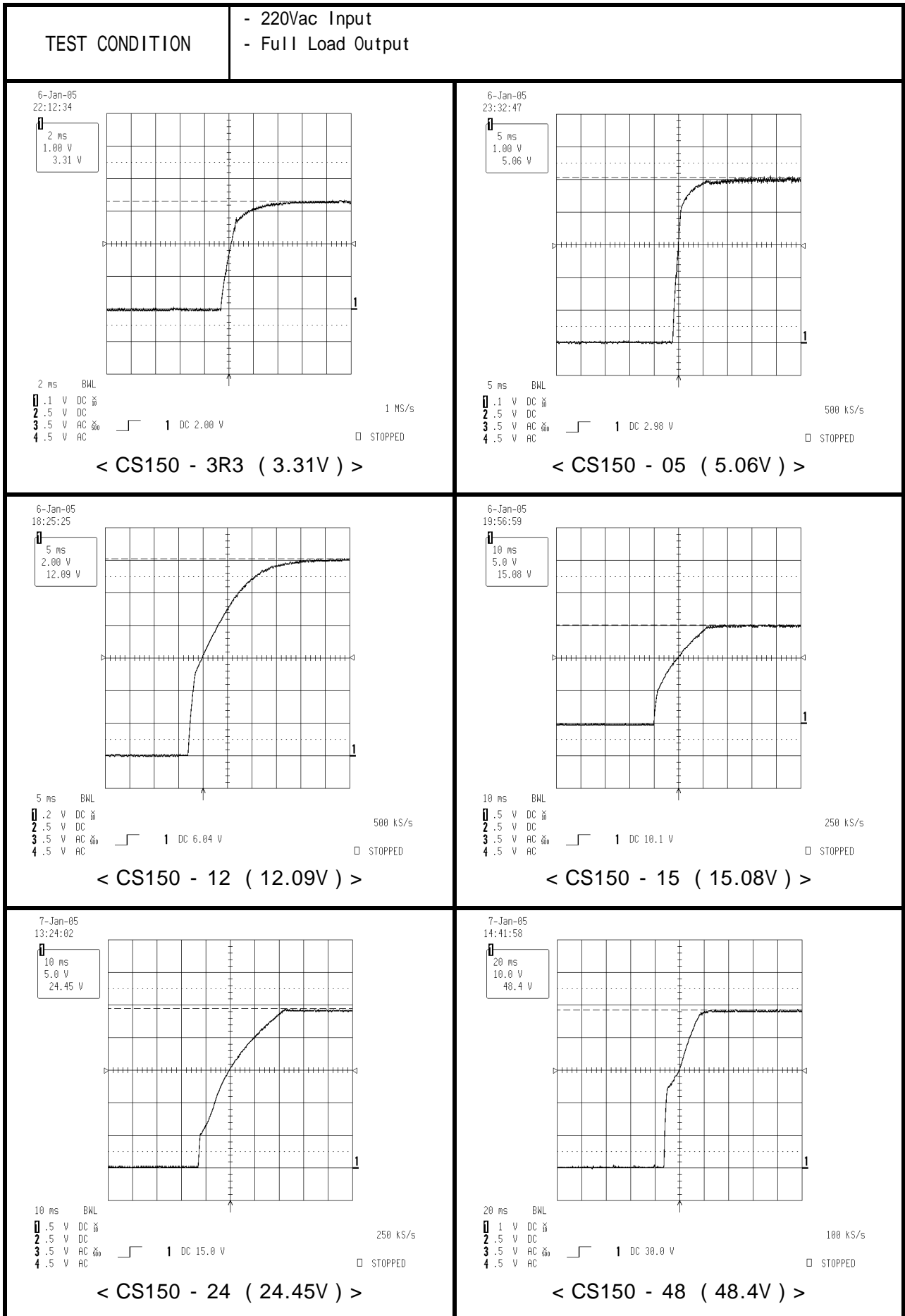

2. Technical Data

2.9 Over Voltage Protection

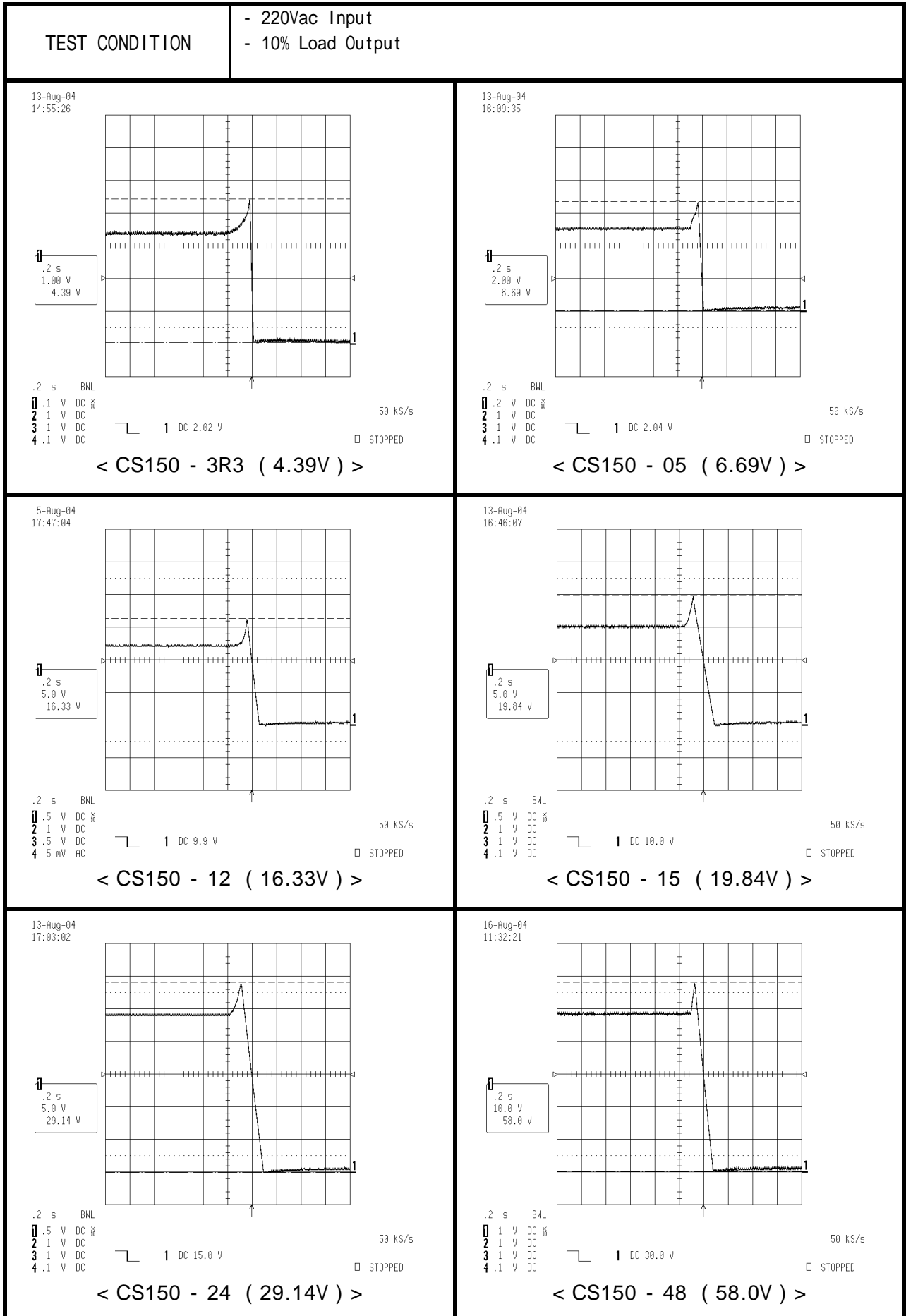

2. Technical Data

2.10

()

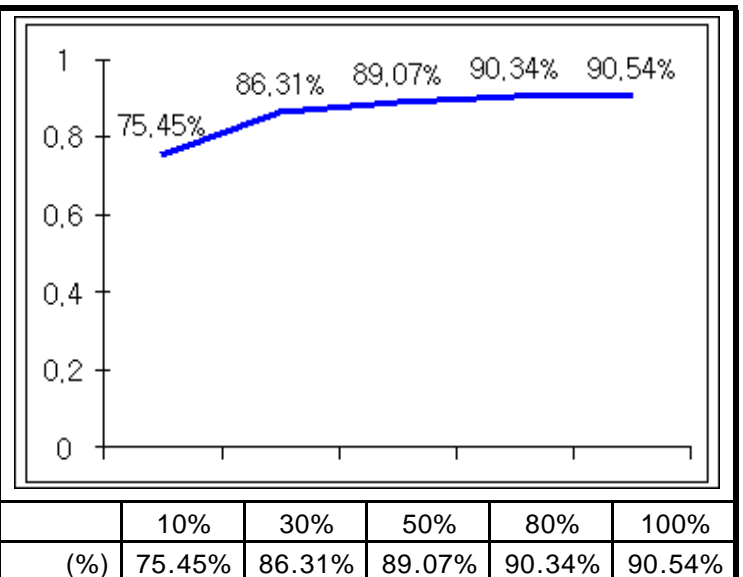
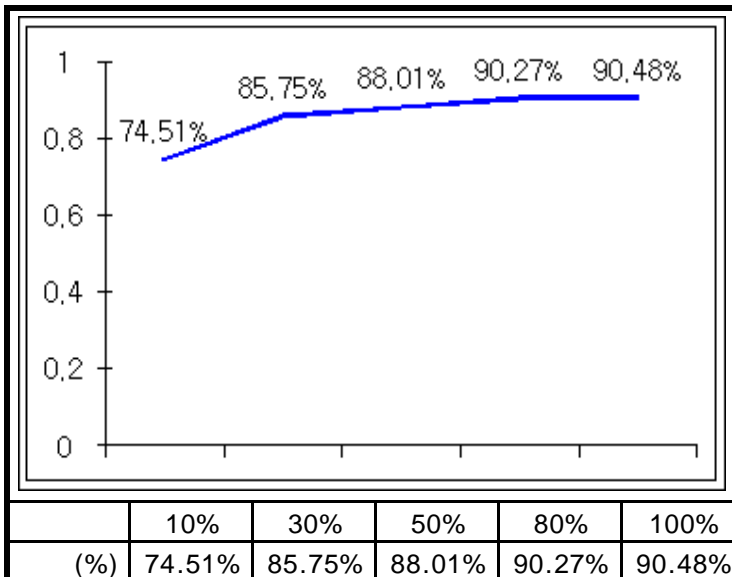
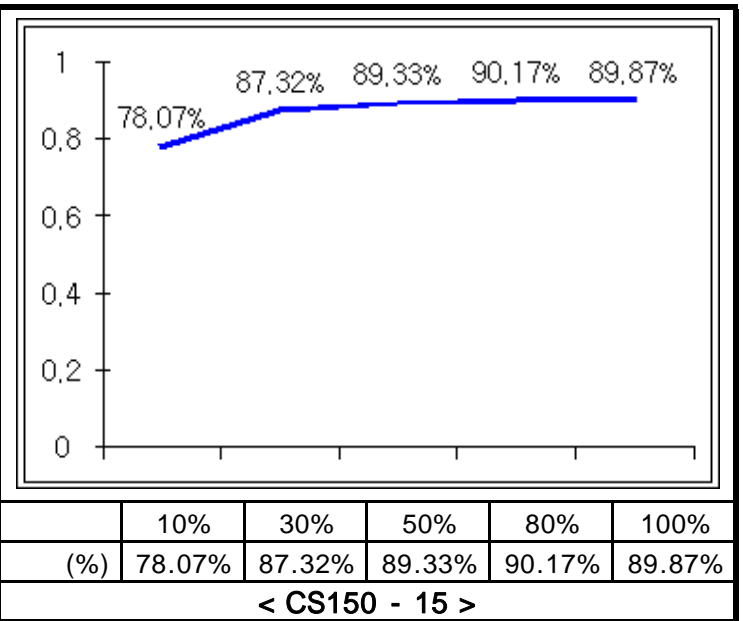
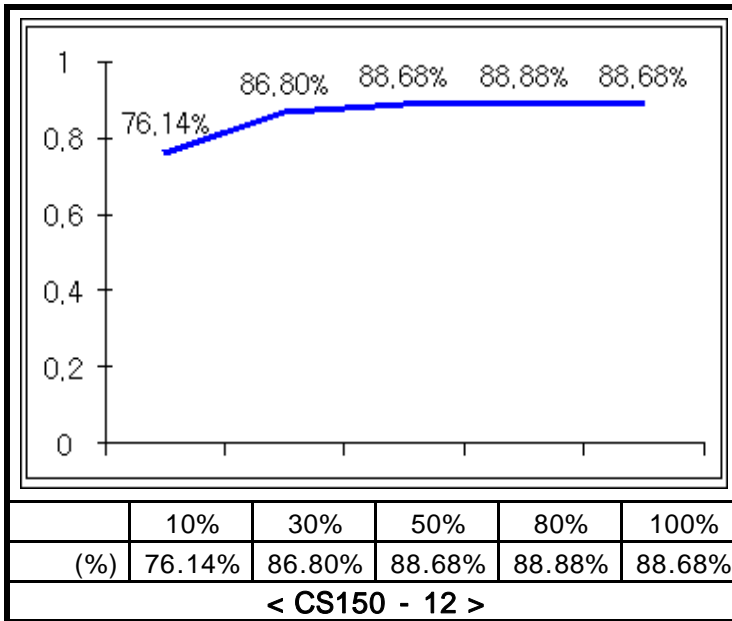
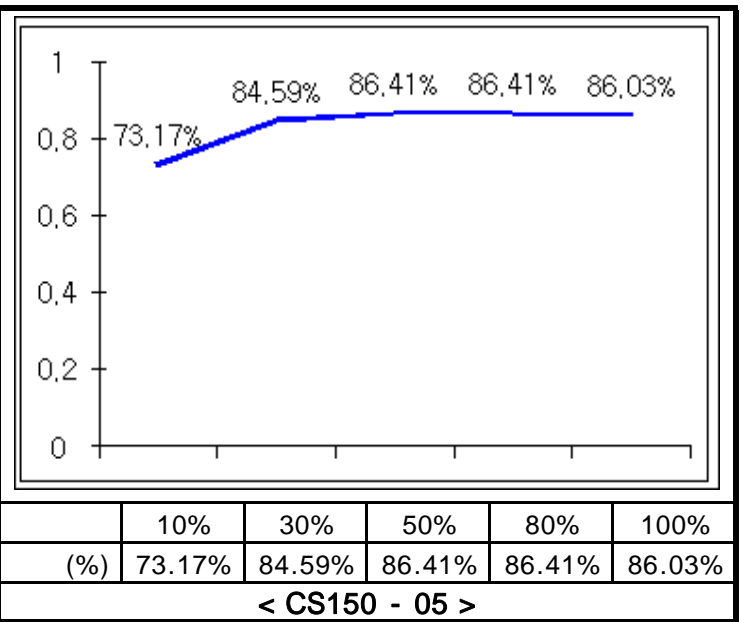
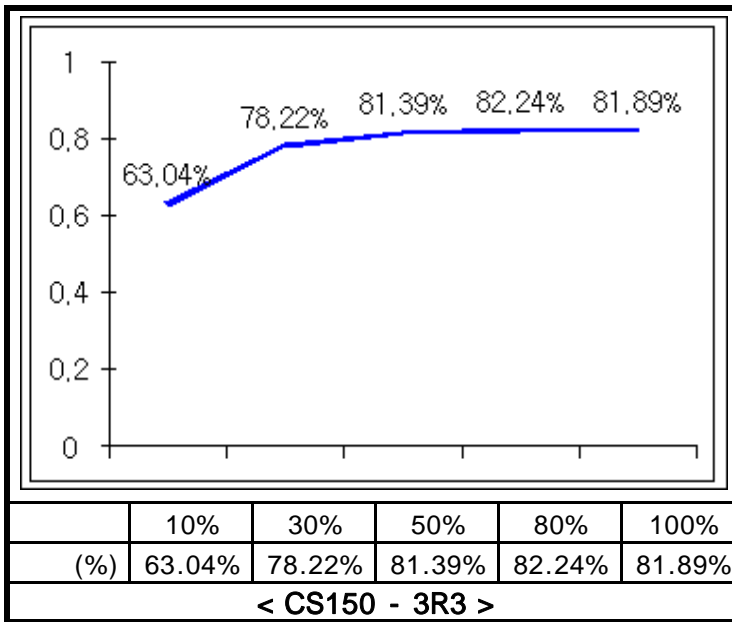

2. Technical Data

< CS150 - 24 >	< CS150 - 48 >
----------------	----------------

2. Technical Data

< CS150 - 24 >

< CS150 - 48 >

3. Case Dimension

